

Volume State Control - A New Approach

W. G. PARKIN

Intensive Care Unit, Monash Medical Centre, Clayton, VICTORIA

ABSTRACT

Objective: *To describe a new approach to circulating volume control in critically ill patients.*

Data sources: *Studies in circulatory physiology, mathematical models of the circulation and open and closed loop circulation control.*

Summary of review: *In evaluation of the volume state it may be wiser to consider the determinants of the systemic venous return rather than those of the cardiac output. These determinants include the mean systemic filling pressure, the right atrial pressure and the unknown resistance to venous return. A model based approach is advanced to determine a mean systemic filling pressure analogue (P_{msa}) which accounts for variation in venous resistance. It is suggested that P_{msa} is an appropriate object of volume control. Definition of a volume state provides insights for cardioactive therapy.*

Conclusions: *Use of a P_{msa} volume signal enables prolonged stable closed loop volume servocontrol. In global heart dysfunction the dimensionless variable $(P_{msa} - RAP)/P_{msa}$ may be used to guide inotropic therapy. (Critical Care and Resuscitation 1999; 1: 311-321)*

Key Words: Mean systemic pressure, fluid therapy, closed loop control, circulation modelling

Control of the volume state is amongst the commonest and most important of acute medical therapies. Yet little formality exists as to what is being controlled, how it is measured or how set points are determined. Definition of the volume state has major implications for therapy, for the understanding of other circulatory manipulation (e.g. vasoactive or inotropic control) and by implication for the quality and integrity of care. The emergence of automatic volume control in the next millennium will depend on a critical understanding of what is being controlled.

A uniform definition of the volume state would have major implications for teaching and comparative research. How can one compare volume control strategies, for example, if we are not agreed upon what is being controlled? In this paper we report that the mean pressure in the systemic circulation, the mean systemic filling pressure (P_{ms}) has great merit as a measure of the volume state and suggest how a mean

systemic filling pressure analogue may be measured and used clinically.

Historical

It was Starling¹ perhaps more than any other, who in enunciating his 'Law of the Heart', promoted a 'cardio-centric' view of circulatory regulation. The inevitable relationship between decline in heart function and reduction in circulatory flow is an almost irresistible paradigm. The 'Law of the Heart', in providing a qualitative relationship between volume loading, ventricular end diastolic volume and stroke volume, provided a rational connection between the 'volume state' and circulatory dynamics.

Yet paradoxically it was the same author who together with Bayliss,² belatedly came to appreciate the importance of (and measure) the steady pressure existing in the stopped circulation. This 'hydrostatic mean pressure' and some appreciation of its role in dynamics

Correspondence to: Assoc. Prof. W. G. Parkin, Intensive Care Unit, Monash Medical Centre, 246 Clayton Rd, Clayton, Victoria 3168

had been described more than forty years previously by Weber.³ That Weber's conclusions were so simple and yet so fundamental led Starling to remark "We asked ourselves why that had not occurred to us before. In fact, they seem to be a part of a forgotten or disregarded chapter in the physiology of the circulation." How fateful do these words seem a century later.

Another fifty years were to pass before Starr and Rawson⁴ postulated a role for Starling's 'mean systemic pressure' in driving the venous return. It was Guyton who formalised this realisation into a quantitative relationship,⁵⁻⁸ viz

$$VR = \frac{P_{ms} - RAP}{RVR}$$

where VR is the venous return, P_{ms} the mean systemic filling pressure, RAP the right atrial pressure and RVR the resistance to venous return. There are a number of matters to note of this equation.

First, it is the circulatory equivalent of Ohm's Law, viz,

$$I = V / R$$

where I the current is directly related to the driving voltage V (or pressure) and inversely related to the resistance R . Given Starling's clear realisation of the importance of P_{ms} , it is perhaps surprising that he did not come to the same understanding.

Second, in identifying a quantitative relationship between P_{ms} (which in the long term is controlled by the kidney) and the circulatory dynamics, this equation stands at the crossroads of sodium/water metabolism and circulatory control. Given the evolution of mammals from marine environments and the development of a hydraulic transport system for gases, it is hard to conceive a more fundamental or unifying equation in physiology. Such quantitation is not a feature of the Starling relationship.

Third, Guyton realised the subtlety of the 'resistance to venous return', depending as it does on compliances and the disposition of the circulation as well as resistance.

Finally, in describing the equation to the venous return curve it was possible to understand the interaction of the (Guytonian) venous return and the (Starling) cardiac response using a graphical approach. This led to further insight.

The last forty years of the millennium have seen little advance in the general application of these ideas. The mean pressure in the circulation is hardly mentioned in clinical practice nor until recently in the clinical literature,⁹ remaining essentially a scientific oddity within undergraduate physiology courses. It is truly 'a forgotten chapter' of medicine.

Though methods of measurement have changed from the right atrial pressure line to the flow directed pulmonary artery catheter to sonic measurement of ventricular volumes, therapeutic volume control remains rooted in the fluid balance chart and the Starling idea of provision of a ventricular preload. The 'volume state' (as opposed to the blood volume) remains numerically undefined, the object of its precise control uncertain.

This paper seeks to show that measurement of a mean systemic filling pressure analogue allows quantitative definition and control of the volume state together with major insight for vasomotor and cardiac regulation.

Analysis of the venous return equation $VR = (P_{ms} - RAP)/RVR$, mean circulatory filling pressure P_{mc} and mean systemic filling pressure P_{ms}

In the filling of distensible tubes such as a tyre or blood vessel a certain amount of volume (V_o) is required merely to fill the vessel to an unstressed state. This involves no pressure rise. Further volume addition (V_e) involves elastic distension of the wall and a pressure rise P dependent on the compliance (C) or 'stretchiness' of the wall, viz

$$P = V_e / C$$

where V_e is the 'stressing' volume and C has the dimension $\Delta V / \Delta P$.

$$V_t = V_o + V_e$$

where V_t is the total volume.

It follows that if a blood vessel is maintained at a positive pressure it includes a stressing volume. Since virtually all vessels in the circulation are at a positive pressure with respect to atmosphere, we may conclude that they are 'over filled'. Thus when the heart is stopped a steady state distending pressure exists in the circulation, the mean circulatory filling pressure P_{mc} . This pressure is normally controlled in the long term by the kidney which maintains an exquisite balance

between sodium input and excretion using the 'principle of infinite gain'.¹⁰ This is a form of integral control.

The normal value of P_{mc} is about 7mmHg in some mammals including man. Since

$$P_{mc} = \frac{V_e}{C} = \frac{V_t - V_o}{C}$$

short term transients in P_{mc} may result from alterations in blood volume V_t , alterations in the unstressed volume V_o (e.g. by muscular veno-constriction) and alterations in vascular compliance C , a function in part of elastic tissue. Of an approximate human adult blood volume (V_t) of five litres, the unstressed volume (V_o) may approximate four liters and the stressing volume (V_e) one litre. The average human circulatory compliance is approximately 100ml/mmHg,¹¹ or 1 - 2 ml/kg/mmHg. For a 70kg subject at 2ml/kg/mmHg

$$P_{mc} = \frac{V_e}{C} = \frac{1000 \text{ ml}}{2 \text{ ml / kg / mmHg} \times 70 \text{ kg}} = \frac{1000 \text{ ml}}{140 \text{ ml / mmHg}} = 7 \text{ mmHg}$$

Since energy sources separate the pulmonary and systemic circulations, the mean systemic pressure P_{ms} may differ from the mean pulmonary filling pressure P_{mp} . The mean circulatory filling pressure will be the volume weighted mean of these two pressures. The mean systemic filling pressure minus right atrial pressure difference drives the systemic venous return while the mean pulmonary filling pressure minus left atrial pressure difference determines the pulmonary venous return. At steady state these venous returns will be essentially equal.

Since the systemic and pulmonary circulations are in series, control of the determinants of the systemic venous return will have the same flow consequences as control of the determinants of the pulmonary venous return. Thus for the vast majority of clinical situations, consideration of the mean systemic filling pressure minus right atrial pressure relationship will provide an

adequate understanding of the influence of volume manipulation upon the circulatory dynamics as a whole.

In terms of blood volume disturbances, the major proportion of the blood volume, perhaps 80%¹² resides in the systemic circulation. Much of the compliance of the global circulation is similarly disposed. Fluid and ion losses from the circulation, both internal fluxes to the interstitium, cells and fluid spaces and external losses through urine formation, sweating, haemorrhage, transudation, exudation or artificial diafiltration are overwhelmingly from the systemic circulation. Similarly, addition of ions and fluid via the gut or vasculature is virtually uniquely via the systemic circulation. The act of such addition exerts its effect upon the circulatory dynamics via the mean systemic filling pressure, P_{ms} . The final disposition of fluid in the circulation will in part be a function of the relative performance of right and left hearts, not the act of addition.

The mean systemic pressure has nothing to do with the operation of the heart (it is present when the heart is stopped) and is independent of circulatory resistance (no flow, no resistance). P_{ms} depends entirely on the stressing volume of the circulation (the difference between the total volume and unstressed volume) and the lumped circulatory compliance.

The right atrial pressure (RAP) - why atrial pressures are not volume signals

The right atrial pressure depends upon the ratio between the excess volume in the right atrium (V_{rae}) and the (cyclically varying) right atrial compliance (C_{ra}), viz

$$RAP = \frac{V_{rae}}{C_{ra}} + P_x$$

where P_x is the pressure external to the right atrium.

Further
$$V_{rae} = V_{ra} - V_{rao}$$

where V_{ra} = total volume in right atrium
and V_{rao} = unstressed volume in right atrium

$$V_{ra} = \int (F_{rai} - F_{rao}) dt$$

where F_{rai} = flow into the right atrium, the venous return
and F_{rao} = flow into right ventricle

Thus the right atrial pressure is dependent upon the determinants of the venous return (P_{ms} , RVR and itself), the performance of the right heart and the pressure

external to the right atrium. Clearly the right atrial pressure (or the left atrial pressure) though a function of the volume state is not dependent on the state of filling alone. Rather, it is determined by a complex interaction of filling, circulatory resistance and ventricular performance. It is not an independent measure of the volume state. Though the right atrial pressure is normally zero,¹³ clearly the volume state is not.

Venous resistance and the resistance to venous return

Referring to figure 1, consider a minimalist model of the systemic circulation in which arterial and venous capacitances C_A , C_V are disposed in relation to the arterial and venous resistances R_A , R_V and $C_V \gg C_A$, $R_A \gg R_V$.

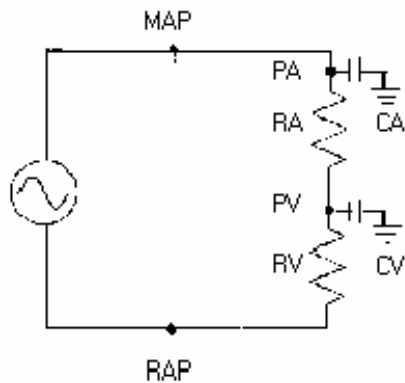

Figure 1. A schematic of the pressures (P), resistances (R) and capacitances (C) in the arterial and venous parts of the circulation

A rise in R_A will capture blood in the low compliance arterial system, elevating the mean arterial pressure. The right atrial pressure and cardiac output will fall. A rise in R_V by contrast will capture blood in the highly compliant venous system, the right atrial pressure and cardiac output will fall. The mean arterial pressure will fall as the flow across R_A falls. A rise in venous resistance R_V is accompanied by a falling blood pressure, cardiac output and right atrial pressure, changes indistinguishable from hypovolaemia, that is, falling P_{ms} . Indeed the two states often co-exist clinically as hypovolaemia and reflex venoconstriction cause a fall in venous diameter. It may be shown theoretically that for any value of R_V there is a circulation with the same blood pressure, cardiac output and right atrial pressure due to change in P_{ms} .

The resistance to venous return RVR (as opposed to the venous resistance R_V) is the resistance encountered by the average element in the circulation in returning to the heart.

Most of the elements in the circulation are in the veins and encounter the venous resistance R_V in returning to the heart. Elements in the arterial circulation

encounter both the arterial resistance R_A and the venous resistance R_V . Clearly RVR will depend not only on the value of R_A and R_V but the relative proportion of the circulatory elements in arterial and venous compartments. For a circulation of n compartments;⁹

$$RVR = \frac{R_1 C_1 + (R_1 + R_2) C_2 + \dots + (R_1 + R_2 + \dots + R_n) C_n}{C}$$

A corollary of this equation is that the resistance to venous return (RVR) may change due to compliance change even though the resistances in the circulation are constant.

Given the clinically immeasurable contribution of R_V to RVR , it might be argued that even if the stopped pressure in the circulation P_{ms} was known, its effect upon the venous return would be uncertain. This may well be where a Guytonian view of the circulation has foundered clinically. We need to find a way to account for the uncertain influence of R_V .

Measurement of a mean systemic filling pressure analogue P_{msa}

Measuring the mean systemic filling pressure by cessation of heart pumping was frequently employed by Guyton and others in animal experiments. This involved fibrillating the heart, hastening the attainment of pressure equilibrium using a pumped external arterio venous conduit, measuring P_{mc} and then defibrillating the heart. Clearly this approach is clinically inappropriate though it is worth recording that very occasionally one observes the mean circulatory filling pressure in practice when the heart stops spontaneously.

Separately we have shown that an effective mean systemic filling pressure analogue P_{msa} may be measured using an equation of the form

$$P_{msa} = aRAP + bMAP + cCO$$

This equation may be derived in the following way.

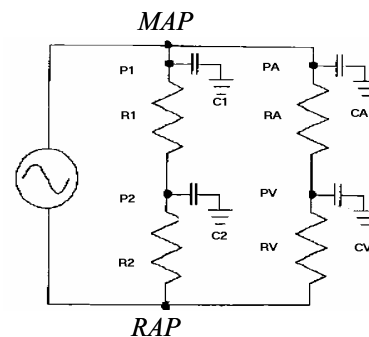

Figure 2. Schematic representation for the parallel circuit used to conceptually solve the problem of measuring a P_{ms} analogue

In previous reports,¹⁴ a method was described for measuring P_{msa} using the mean blood pressure, right atrial pressure, cardiac output and anthropometric data. It is appropriate to review the main elements of that method.

Data from modelled circulations suggests that, in the normal situation, the stopped pressure in regional systemic circulations closely approximates that in the global systemic circulation. If this were not true, the regional circulation would empty into the general circulation or vice versa. In regional venous obstruction, for example, this equality is no longer true leading to local fluid accumulation. The regional circulation is a fractal of the general circulation.

This observation suggests a method for measuring P_{msa} . If a normal limb were to undergo instantaneous arterial and venous clamping, the vascular equilibrium pressure in the limb would closely approximate P_{ms} . Such repeated clamping would, however, be uncomfortable and the equilibrium point uncertain. The limb circulation may be viewed as a resistance capacitance network linking the aorta to the right atrium. If we knew the values of these resistances and capacitances, we could model the hydraulic characteristics of the limb with a notional mathematical tube linking the aorta to the right atrium in parallel with the systemic circulation. ‘Clamping’ the ends of this tube would result in an equilibrium pressure equal to the P_{ms} . Figure 2 shows such an arrangement. R_A , R_V , C_A and C_V respectively represent the lumped systemic arterial and venous resistances and capacitances. R_1 , R_2 , C_1 and C_2 respectively represent the arterial and venous resistances and capacitances of the model tube. If $R_1/R_2 = R_A/R_V$ and $C_1/C_2 = C_A/C_V$ then the clamped pressure in the model tube

$$P_{\text{model}} = \frac{P_1 C_1 + P_2 C_2}{C_1 + C_2}$$

would equal the mean pressure

$$P_{ms} = \frac{P_A C_A + P_V C_V}{C_A + C_V}$$

in the patient’s circulation.

The obvious question is: “How may one know the resistances R_A , R_V and the capacitances C_A , C_V in the patient’s systemic circulation in order to set R_1 , R_2 , C_1 , and C_2 in the model line?” Clearly R_A , R_V , C_A , and C_V are continually changing in the patient in response to physiological, pathological, and therapeutic influences.

First, consider their values in the normal resting physiological state. In doing so, five concepts are considered.

Concept 1. P_{ms} has a normal value of 7 to 8 mmHg. This value is both extrapolated from animal experiments and is the value found in a well-validated model of the human circulation.

Concept 2. The right atrial pressure is normally very close to zero.

Concept 3. The systemic arteriovenous resistance ratio is the same for normal people at rest. This would appear necessary if the capillary hydrostatic pressure, a determinant of the disposition of fluid between intravascular and extravascular sites, is to be equal between individuals of different size and cardiac output. These resistances operate as a ‘voltage divider’. We note that differently sized normal people of the same age and with the same mean blood pressure/right atrial pressure difference have widely disparate resting cardiac outputs. A larger person has more arteriovenous circulatory elements operating in parallel, and thus the overall circulatory resistance is lower. Both the arterial and venous components of resistance are lower than in a smaller person. The mean arteriovenous resistance ratio is presumably the same.

Concept 4. The arteriovenous compliance ratio is the same for normal people at rest. If concepts 1, 2 and 3 are true and the patient has a normal mean blood pressure, this follows mathematically.

Concept 5. A change in venous resistance R_V produces effects upon the right atrial pressure, cardiac output and mean arterial pressure identical to those seen with some change in P_{ms} of opposite sign.

Constructing the Model Line

Referring to Figure 2 the parameters of the model line may be determined.

Setting R_1 . Because $R_A \gg R_V$, R_A approximates the systemic vascular resistance (SVR) where

$$SVR = \frac{MAP - RAP}{CO}$$

and MAP is mean arterial pressure and CO is cardiac output. Thus, if the cardiac output is known, R_1 may be set to the SVR of the patient at the time.

Setting R_2 . By contrast, R_V the patient’s venous resistance, is not measurable. We can calculate the patient’s resting normal value of R_V by knowing the patient’s resting normal SVR and resting normal arteriovenous resistance ratio. The resting SVR is known from the resting normal age-dependent mean blood

pressure and cardiac output and assuming a normal right atrial pressure of zero. We have set the resting arteriovenous resistance ratio to 25:1. The value of this ratio depends upon where the arteriovenous division point is placed. Other values may be chosen, provided that the chosen arteriovenous compliance ratio results in

$$\frac{P_A C_A + P_V C_V}{C_A + C_V} = 7 - 8 \text{ mmHg} = P_{ms}$$

(from concept 1) in the patient's normal state.

If we choose a resting normal arteriovenous resistance ratio of 25:1, the patient's resting normal value of R_V is 1/26 of the SVR . If the resting normal mean blood pressure is 100, the venoarterial compliance ratio would be 24:1 if the P_{ms} is 7.5.

Of course, the patient's value of R_V varies from the normal resting value in response to a plethora of stimuli. This variation is not measurable. To circumvent this difficulty, assume that R_V does not change from its normal value in the patient and that, when it actually does, the dynamic change produced derives from a change in P_{ms} (Concept 5). We assert that the two types of change are clinically indistinguishable. An increase in venous resistance is dynamically indistinguishable from covert blood loss. The practical consequence for the design of the test line is that R_2 is fixed to the resting normal value of R_V for the patient in question, based on anthropometric data.

Setting C_1 and C_2 . C_1 and C_2 are set such that the ratio C_1/C_2 is the same as the patient's normal resting compliance ratio. Clearly, C_A and C_V will individually vary in the patient in response to a plethora of stimuli. Assume initially that C_A and C_V vary so that the ratio C_A/C_V is unchanged and that $C_1/C_2 = C_A/C_V$. Under these conditions, the dynamic and static identity of patient and test line would not be breached.

Separately, consider what would happen if C_V the patient's venous compliance, alone increased (i.e. $C_A/C_V \neq C_1/C_2$). The right atrial pressure, mean blood pressure, and cardiac output would decrease and the decrease in static pressure in the test tube would identify that the patient was becoming hypovolaemic. If we now administer volume to the patient until the pressure P_V in the venous capacitance C_V is restored, all the circulatory dynamics will be exactly restored, and the test line will record a return to the initial P_{msa} . The volume deficit has been replaced. The patient's P_{ms} has, however, decreased as the quotient

$$\frac{P_A C_A + P_V C_V}{C_A + C_V} = P_{ms}$$

is reduced by increasing C_V . Consideration of the venous return equation provides an explanation, namely,

$$VR = \frac{P_{ms} - RAP}{RVR}$$

VR and RAP are unchanged because the dynamics have been restored. P_{ms} is reduced and the equality is maintained because RVR is reduced. Note that this has occurred with no change in the magnitude of R_A or R_V . With increased filling of the venous circulation, the average circulatory element has moved downstream, and the resistance encountered by that element in returning to the right atrium (i.e. RVR) is reduced. This underlines the uncertain quantitative influence upon the circulatory dynamics of P_{ms} even if it were clinically measurable by stopping the heart. By contrast, P_{msa} has guided the appropriate restoration of the circulatory volume.

Thus, all combinations of patient compliance changes could be seen as the sum of two components where C_A and C_V are varying in an unknown way, namely, 1) change in C_A , C_V which maintains $C_A/C_V = C_1/C_2$ and, 2) isolated change in C_V .

From the above, it is clear that the P_{ms} and the P_{msa} are numerically different when, 1) the patient's arteriovenous compliance ratio differs from normal and/or, 2) the patient's venous resistance is varying. P_{msa} would nonetheless appear to correctly identify the volume dependent element of circulatory dynamic change if the term 'volume dependent' is allowed to embrace the influence of venous resistance change.

The input variables to measurement of this pressure are anthropometric (age, height, weight, allowing measurement of the normal resting SVR , see above) and the mean blood pressure, right atrial pressure and cardiac output.

In summary, the above description defines a P_{msa} . Unlike P_{ms} which is measured by stopping the heart and which depends only on the circulatory stressing volume and the lumped circulatory compliance, P_{msa} embraces change in the venous resistance. This is a consequence of the way in which it is derived. In that P_{ms} and P_{msa} are not numerically equal under certain circulatory conditions, validation of P_{msa} by stopping the circulation of animals may not be possible. Thus P_{msa} reflects a lumped view of the circulation in which changes in blood volume, arterial and venous compliance and venous resistance are seen as changes in the effective intravascular volume state.

P_{msa} is thus a function of the right atrial pressure, mean arterial pressure and cardiac output because

$$P_{msa} = \frac{P_1 C_1 + P_2 C_2}{C_1 + C_2}$$

if $x = C_2/C_1$ the normal resting venoarterial compliance ratio

$$\begin{aligned} P_{msa} &= \frac{P_1 C_1 + P_2 C_2}{C_1 + C_2} \\ &= \frac{C_1 (P_1 + xP_2)}{C_1 (1 + x)} \\ &= \frac{P_1 + P_2 x}{1 + x} \end{aligned}$$

but

$$P_2 = \frac{R_2 \cdot MAP + R_1 \cdot RAP}{R_1 + R_2}$$

and

$$R_1 + R_2 = \frac{MAP - RAP}{y \cdot CO}$$

where y is the fraction of the cardiac output that flows through R_1 and R_2 .

$$\begin{aligned} y &= \frac{R_A + R_V}{R_1 + R_2} \\ &= \frac{R_V}{R_2} \end{aligned}$$

when R_V has its resting normal value in the patient and $R_A/R_V = R_1/R_2$. Substitution and rearrangement leads to

$$\begin{aligned} P_{msa} &= \frac{x}{(1+x)} \cdot RAP + \frac{1}{(1+x)} MAP + \frac{x}{(1+x)} R_2 \cdot y \cdot CO \\ &= \frac{x}{(1+x)} RAP + \frac{1}{(1+x)} MAP + \frac{x}{1+x} \cdot R_V \cdot CO \end{aligned}$$

i.e.

$$P_{msa} = aRAP + bMAP + cCO$$

where a and b are non dimensional constants and c is a patient age, size dependent variable with the dimensions of resistance (resistance x flow (CO) = pressure). Importantly P_{msa} embraces unmeasurable change in the

venous resistance. If x , the venoarterial compliance ratio is chosen as 24:1 and the arteriovenous resistance ratio is 25:1 then $a = 0.96$, $b = 0.04$ and $c = 0.96 \times 1/26$ normal resting SVR (mmHg/L/min), viz

$$P_{msa} = 0.96 RAP + 0.04 MAP + cCO$$

c typically varies between 0.3 (large young patient) and 1.2 (diminutive elderly patient). As a corollary, a certain absolute value of the cardiac output has greater volume implications for an older, smaller individual. In a normal young patient with $c = 0.5$

$$RAP = 0, MAP = 100, CO = 6$$

$$\begin{aligned} P_{ms} &= 0.96(0) + 0.04(100) + 0.5(6) \\ &= 0 + 4 + 3 \\ &= 7 \end{aligned}$$

The component of the volume state P_{msa} depending on the RAP term is zero when $RAP = 0$ and (in a Starling heart) increases as a proportion of P_{msa} as the right atrial pressure increases. At high right atrial pressures P_{msa} may be dominated by the RAP component, leading to (inappropriate) use of the RAP as the volume signal. When heart function ceases and $CO = 0$

$$P_{msa} = RAP = MAP$$

i.e.

$$P_{msa} = 0.96RAP + 0.04MAP + c(0)$$

The approach to measurement of P_{msa} leads to a parsimonious view of the circulation of great utility. The prime measured circulatory dynamic variables are each seen to have three determinants (Table 1).

Table 1. Circulatory dynamic variables.

<i>The volume state (P_{msa})</i>
blood volume
unstressed volume
stressing volume
compliance
(venous resistance)
<i>The arterial resistance state (SVR)</i>
arterial resistance
<i>The heart performance state (HP)</i>
chronotropy
rhythm
inotropy
other determinants

Determination of the heart performance

The mean arterial pressure or cardiac output, for example, each depend on volume, resistive and cardiac determinants. Identification of a volume state signal might thus be expected to yield insights with respect to the global performance of the heart. Since

$$VR = \frac{(P_{ms} - RAP)}{RVR}$$

when volume is administered to a subject with the aim of improving circulatory dynamics (as opposed to replacing volume loss), increase in venous return will depend upon changing the mean systemic filling pressure minus right atrial pressure difference and/or decreasing the venous resistance component of the resistance to venous return.

Since P_{msa} already embraces the influence of change to the venous resistance (and therefore RVR), volume therapy is directed at producing a change

$$\Delta(P_{msa} - RAP)$$

in response to the volume input

$$\Delta(P_{msa})$$

The ratio between these changes is a dimensionless measure of the efficiency E of the heart in converting a volume input into improved dynamics, viz

$$E = \frac{\Delta(P_{msa} - RAP)}{\Delta(P_{msa})}$$

It is suggested that it is this efficiency which is the appropriate object of inotropic control.

For a constant value of P_{msa} and c , the cardiac output coefficient (single subject), the equation

$$0.96RAP + 0.04RAP + cCO = K = P_{msa}$$

is the equation to a plane in the $RAP/MAP/CO$ space. Planes of constant heart performance for which

$$\frac{P_{msa} - RAP}{P_{msa}}$$

is constant may be drawn in this space; in these planes

$$\frac{\Delta(P_{msa} - RAP)}{\Delta P_{msa}}$$

is constant. Planes of constant heart performance intersect the P_{msa} plane along lines of constant RAP . The dimensionless heart performance number

$$HP = \frac{P_{msa} - RAP}{P_{msa}}$$

has a value of unity when RAP has its normal value of zero and zero when $RAP = P_{ms}$. As expected in a Starling heart, the efficiency (HP) of conversion of volume loading into dynamics becomes less with increase in the volume state. By contrast, from model experiments using a heart with a linear function curve, viz

$$SV = K \cdot (RAP)$$

where SV is the stroke volume, HP is constant.

Power – matching the heart to the circulation

The hydraulic power output of the heart W is given by

$$W = MAP \cdot CO$$

Change in the arterial resistance allows a given power to be delivered at a wide range of pressure/flow combinations. Table 2 shows such an arrangement for a hydraulic power of 440 mmHg.L⁻¹.min⁻¹ at a P_{msa} of 20 in an elderly patient in which the value of c (cardiac output coefficient in the P_{msa} equation) is 1. It is noted that there is a systemic vascular resistance, about 1600 to 1800, for which the heart performance

$$\frac{P_{ms} - RAP}{P_{ms}}$$

is a minimum. Table 3 shows the arrangement for a hydraulic power of 610 mmHg.L⁻¹.min⁻¹ at a P_{ms} of 10 in a young patient in which the value of c is .35. The heart performance is a minimum for this power in this patient at an SVR of approximately 600. It is suggested this may be an appropriate technique for optimising vasoactive therapy for a given heart power though this is presently untested.

Table 2. Heart performance variance in an elderly diminutive patient with hydraulic power of 440 mmHg.L.min⁻¹ at different systemic vascular resistance

P_{ms}	PWR	MAP	CO	HP	SVR	C
20	440	40	11	0.615	234	1
20	440	50	8.8	0.521	367	1
20	440	60	7.33	0.465	537	1
20	440	70	6.29	0.432	746	1
20	440	80	5.5	0.411	992	1
20	440	90	4.89	0.4	1276	1
20	440	100	4.4	0.396	<u>1598</u>	1
20	440	110	4	0.396	1958	1
20	440	120	3.67	0.399	2356	1
20	440	130	3.38	0.405	2791	1

Table 3. Heart performance variance in a young patient with hydraulic power of 610 mmHg.L.min⁻¹ at different systemic vascular resistance

P_{ms}	PWR	MAP	CO	HP	SVR	C
10	610	40	15.3	0.681	193	0.35
10	610	50	12.2	0.611	302	0.35
10	610	60	10.2	0.579	439	0.35
10	610	70	8.71	0.568	<u>602</u>	0.35
10	610	80	7.63	0.57	794	0.35
10	610	90	6.78	0.58	1012	0.35
10	610	100	6.1	0.597	1258	0.35
10	610	110	5.55	0.619	1531	0.35
10	610	120	5.08	0.644	1832	0.35
10	610	130	4.69	0.671	2160	0.35

PWP = pulmonary wedge pressure, MAP = mean arterial pressure, CO = cardiac output, SVR = systemic vascular resistance, C = vascular compliance, P_{ms} = mean systemic filling pressure

Clinical application

P_{msa} is an early example of a therapeutic signal obtained by modelling as opposed to direct measurement. In order to test the validity of the model we have conducted a series of closed loop control experiments during continuous veno venous haemodiafiltration (CVVHDF) having first obtained institutional ethics committee approval. Closed loop control experiments impose a particular level of objectivity as, without intervention, patient stability is critically dependent upon test signal integrity.

In one study,¹⁴ 10 critically ill patients (mean APACHE score 29.7, range 21 - 33) with multi system organ failure including acute renal failure were volume servo controlled while on CVVHDF. All were on inotropic and/or vasoactive drug infusions and all had

Swan Ganz catheters placed. The mean arterial pressure and right atrial pressures were measured each 5 seconds and used with the 1 hourly cardiac output to calculate, using a laptop computer, a 5 second P_{msa} . The last 6 values of this signal, the 30 second average P_{msa} was used each 5 seconds to open or close a purpose built electronic clamp on the gravitational fluid replacement line (4L/h open flow) according to whether P_{msa} was above or below the servo control P_{msa} set point. No knowledge of the fluid lost by the patients (on average 690 ml/h) or gained by replacement or other therapy was available to the controller. After 601 hours of therapy during which 417 litres of diafiltrate were lost and 409 litres of replacement and nutritional fluids administered, the measured external fluid balances of the patient group were within 2% of zero. The tonicity of these patients

was controlled dialytically. The stability of cardiovascular variables during P_{msa} based replacement was tested by comparing sequential 12 hour periods of conventional (isovolume replacement) and P_{msa} based control. Cardiovascular stability during P_{msa} based control exceeded that for conventional control for all variables tested (MAP , RAP , CO , $PCWP$, PAP) except for PAP in which the stability was the same.

Satisfactory circulatory stability has been demonstrated over weeks of closed loop CVVHD servo control. The major difficulty encountered in this work is the critical positioning of pressure transducers on the phlebostatic axis during and after patient movement. Use of continuous cardiac output catheters reduces the burden of cardiac output measurement which is more frequently available to the controller.

In further studies,¹⁵ the present and desired circulations together with the corresponding present and desired P_{msa} , SVR and heart performance HP were listed on a computer display/figure. Manipulation of the volume, vasoactive and heart performance variables were then conducted using a computer guided, open loop approach to acquire the desired circulation. A practical problem with this approach is short term down regulation of the volume state; this is easily achievable if the patient is on CVVHD. Satisfactory acquisition of a desired circulation may be demonstrated for modest variance using 'state-based' control.

Thus it is clear that a state based controller:

1. can maintain systemic volume stability P_{msa} and cardiovascular stability in the long term in the presence of a high, continuous unknown loss of circulating volume,
2. provides a rational basis for chronotropic/inotropic use based on a heart performance variable.

$$\frac{P_{ms} - RAP}{P_{ms}}$$

In this regard we have used a value of 0.3 - 0.4 as the 'dead band' of the heart performance controller, and,

3. provides a rational basis for arterial resistance control (vasoactive use) based on the SVR , particularly in indicating optimal SVR bands for a given circulatory power in a patient of known size and age.

The use of such approaches may be promoted by the emergence of non invasive techniques for measuring cardiac output. These methods include the derivative Fick technique¹⁶ using airway carbon dioxide, oesophageal Doppler and pulse contour methods calibrated with the former. It will be interesting to see

the new place for the flow directed pulmonary artery catheter. In reports indicating the low or no positive influence of such catheters upon outcome,¹⁷ uncertainty is expressed as to whether this is due to the complications of catheter use or the way in which the acquired data is used.

There are remaining difficulties with a P_{msa} based approach to circulatory dynamics. Disorders that produce a rise in the pressure outside the right atrium, that is, causes of a raised intrathoracic pressure and/or intrapericardial pressure or restriction, will clearly result in the heart performance variable

$$\frac{P_{ms} - RAP}{P_{ms}}$$

being falsely low. Careful exclusion of such causes is necessary before using this signal for chronotropic /inotropic control. This problem is of course not unique to this approach.

Patients with severe diastolic dysfunction may need to be identified using TOE or other techniques so that their need for a high target P_{msa} may be identified. Ultrasound, left atrial pressure and/or intrathoracic blood volume measurement may be needed to define patients where, because of severe left ventricular systolic dysfunction, the pulmonary filling pressure significantly exceeds P_{msa} . With an appropriate P_{msa} defined, the systemic filling pressure may again become the object of control of infusions into the systemic circulation.

Summary

An alternative view of circulatory dynamics is presented based on determinants of the venous return rather than the cardiac output. This approach is model based with the shortcomings and assumptions of a simplified DC model based approach. The advantage of the approach is seen as the development of state variables which are usually orthogonal with therapeutic control. The state variables have been used successfully in prolonged closed loop volume control and in open-loop three dimensional control.

This approach has wide applicability in the 'process control' environment of the new Intensive Care Unit. Particularly, P_{msa} is a parsimonious description of the volume state. The approach is seen as having particular utility with the emergence of non invasive techniques for measuring cardiac output. In such circumstances the left atrial pressure will be unknown. The development of the heart performance concept is based on a single chamber view of the heart which will often be valid. There are nonetheless a range of circulatory states where use of P_{msa} and its derivatives may provide an inadequate

description of the circulation. Notably these involve local disorders of the heart. They will require adjunctive techniques.

Received: 20 August 1999

Accepted: 30 August 1999

REFERENCES

1. Starling EH. The Arris and Gale lectures. Some points in the pathology of heart disease. *Lancet* 1897;1:652-655.
2. Bayliss WM, Starling EH. Observations in venous pressure and their relationship to capillary pressures. *J Physiol* 1894;16:159-202.
3. Weber E. The law of pulsatile flow and its application to the circulation. Primitive model of the circulation (German). In: *Berichte ueber die Verhandlungen der Konigl Sachsischer Cesellschaften der Wissen-Schaften zu Leipzig*. Wedmanische Buchhandlung, 1850.
4. Starr I, Rawson AJ. Role of the "static blood pressure" in abnormal increments of venous pressure, especially in heart failure. I. Theoretical studies on an improved circulation schema whose pumps obey Starling's law of the heart. *Am J Med Sci* 1940;199:27-39.
5. Guyton AC, Polizo D, Armstrong GG. Mean circulatory filling pressure measured immediately after cessation of heart pumping. *Am J Physiol* 1954;179:261.
6. Guyton AC. Determination of cardiac output by equating venous return curves with cardiac response curves. *Physiol Rev* 1955;35:123.
7. Guyton AC, Lindsey AW, Kaufmann B. Effect of mean circulatory filling pressure and other peripheral circulatory factors on cardiac output. *Am J Physiol* 1955;180:463.
8. Guyton AC, Lindsey AW, Abernathy JB, Richardson TQ. Venous return at various right atrial pressures and the normal venous return curve. *Am J Physiol* 1957;189:609.
9. Jacobsohn E, Chorn R, O'Connor M. The role of the vasculature in regulating venous return and cardiac output: historical and graphical approach. *Can J Anaesth* 1997;44:849-867.
10. Guyton AC, Coleman TG. Infinite gain feature of the kidney - blood volume pressure regulator, the three laws of long term arterial pressure regulation, renal servo control of arterial pressure. In: Guyton AC. *Circulating physiology III Arterial pressure and hypertension*. Philadelphia: WB Saunders Company; 1980:117-125.
11. Guyton AC. Physics of blood, blood flow and pressure: hemodynamics. In: Guyton AC. *Textbook of Medical Physiology*. 7th ed. Philadelphia: WB Saunders Company; 1986:215.
12. Guyton AC. Cardiac failure. In: Guyton AC. *Textbook of Medical Physiology*. 7th ed. Philadelphia: WB Saunders Company; 1986:309.
13. Guyton AC. The systemic circulation. In: Guyton AC. *Textbook of Medical Physiology*. 7th ed. Philadelphia: WB Saunders Company; 1986:221.
14. Parkin WG, Wright CA, Bellomo R, Boyce N. Use of a mean systemic filling pressure analogue during the closed loop control of fluid replacement in continuous haemodiafiltration. *J Crit Care* 1994;9:124-133.
15. Parkin WG, Wright CA. Three dimensional closed loop control of the human circulation. *Int J Clin Monit Computing* 1991; 8:35.
16. Capek JM, Roy RJ. Non invasive measurement of cardiac output using partial CO₂ rebreathing. *IEEE Trans Biomed Eng* 1988; 35:9.
17. Connors AF Jr, Speroff T, Dawson NV, et al. The effectiveness of right heart catheterization in the initial care of critically ill patients. SUPPORT Investigators. *JAMA* 1996;276:889-897.